



Advanced Managed Platform™

Quick Start Guide AMP5091 4U Platform

Performance Technologies
205 Indigo Creek Drive
Rochester, NY 14626 USA
585.256.0248
support@pt.com

www.pt.com

© 2008 Performance Technologies, Inc.
All Rights Reserved.



Document Revision History

Revision Date	Revision History
11/30/05	Initial Release
09/15/08	Reformatted and refreshed.

Copyright Notice

© Copyright 2008 by Performance Technologies, Inc. All Rights Reserved.

The Performance Technologies logo is a registered trademark of Performance Technologies, Inc. All other product and brand names may be trademarks or registered trademarks of their respective owners.

This document is the sole property of Performance Technologies Inc.

Disclaimer

This document presents information for users of Performance Technologies Inc. products. Although the information contained within this document is considered accurate and characteristic of the subject product, Performance Technologies Inc. reserves the right to make changes to this document and any products described herein to improve reliability, functionality, or design. Performance Technologies Inc. does not assume any liability arising out of the application or use of any product or circuit described herein. No part of this document may be copied or reproduced in any form or by any means without the prior permission of Performance Technologies Inc.

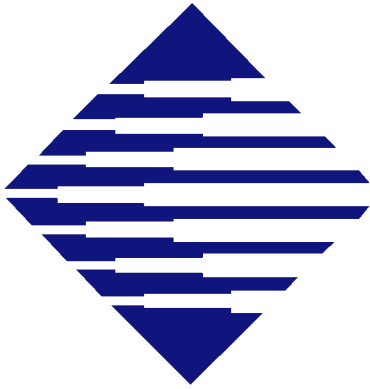

Contents

Chapter 1: Basic Platform Configuration	7
Overview	7
Configuring the Hardware	8
Chassis Hardware Configuration - 4U Chassis, AMP5091	9
ISM Hardware Configuration	12
Ethernet Switch Hardware Configuration	13
Power up the System	13
Chapter 2: Setting Up the Components	17
Overview	17
Ethernet Switch Set-up	17
ISM Set-up	18
Configuring the ISM on a Local Network	19
Setting up the ISM Graphical User Interface (GUI)	21
Chapter 3: Communicating Between Components	23
Overview	23
Working with the ISM	23
Using ISM CLI Commands - Operational Information	23
Using the ISM GUI	24
Using Boot Environment Variables - Configuring the ISM	25
Working with the Ethernet Switches	25
Using the Ethernet Switch CLI Commands - Operational Information	25

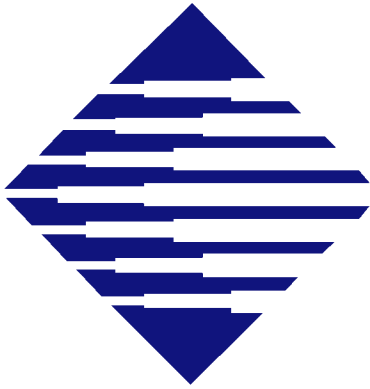

Figures

Figure 1-1: Typical AMP System with a Loaded AMP5091 Chassis — Front View	8
Figure 1-2: Typical AMP System with a Loaded AMP5091 Chassis — Rear View	9
Figure 1-3: BD_SEL# Jumper Locations (J21-J28)	10
Figure 1-4: V I/O Selection	11
Figure 1-5: IPMB Power Selection.	12
Figure 1-6: AC Input Panel	14
Figure 1-7: DC Input Panel	15
Figure 2-1: ISM Front Panel	19
Figure 2-2: ISM GUI Display Screen	22

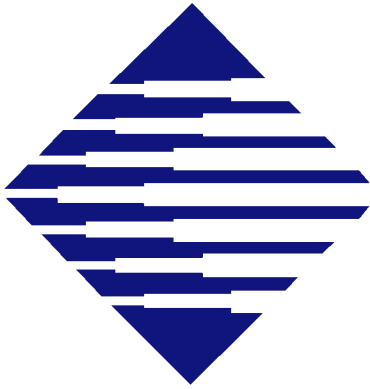

Basic Platform Configuration

Overview

This document was created to help organize and simplify the initial set up a Performance Technologies' Advanced Managed Platform system. The basic Advanced Managed Platform consists of

- one PICMG 2.16 or ATCA compliant chassis (including power supplies and cooling fans)
- one or two Intelligent Shelf Managers (ISMs)
- one or two 10/100/1000 fabric Ethernet switches

The flexible and scalable Advanced Managed Platform offering supports a wide range of communications and embedded applications by delivering reliable, intelligent and comprehensive management throughout all active platform components.

The Advanced Managed Platform offering is designed specifically for high availability solutions. Examples include wireless applications (3G mobile switching centre, GGSN or radio network controller), IP telephony (gateways, switches or server clusters), Wi-Fi gateway/switches, business-critical server clusters (transaction processors) and military communication systems.

These instructions will cover the basic steps to set up a system; set up the hardware (switches and jumpers), power up the chassis, set up the components (software), and finally communicate between the components.

The key topics in this chapter include:

- [“Configuring the Hardware,” on page 8](#)
- [“Chassis Hardware Configuration - 4U Chassis, AMP5091,” on page 9](#)
- [“ISM Hardware Configuration,” on page 12](#)
- [“Ethernet Switch Hardware Configuration,” on page 13](#)
- [“Power up the System,” on page 13](#)

User Manual

This document does not intend to take the place of the user manuals for any component in your system. Please refer to the following hardware manual for all safety information related to connecting and using this equipment, as well as detailed information for the configuration, programming, or usage of the specific elements of your AMP platform.

- *AMP5091 4U General Purpose Packet-Switched Platform Hardware Manual*

Configuring the Hardware

Prior to installing the hardware, refer to your chassis *Hardware Manual* for details regarding to the instructions described in this chapter. This is an important step as there are specific safety aspects to wiring power and ground with these systems.

Figure 1-1, “Typical AMP System with a Loaded AMP5091 Chassis — Front View,” and Figure 1-2, “Typical AMP System with a Loaded AMP5091 Chassis — Rear View,” on page 9 show a typical AMP system using a CPC5086, 12U chassis type.

Figure 1-1: Typical AMP System with a Loaded AMP5091 Chassis — Front View

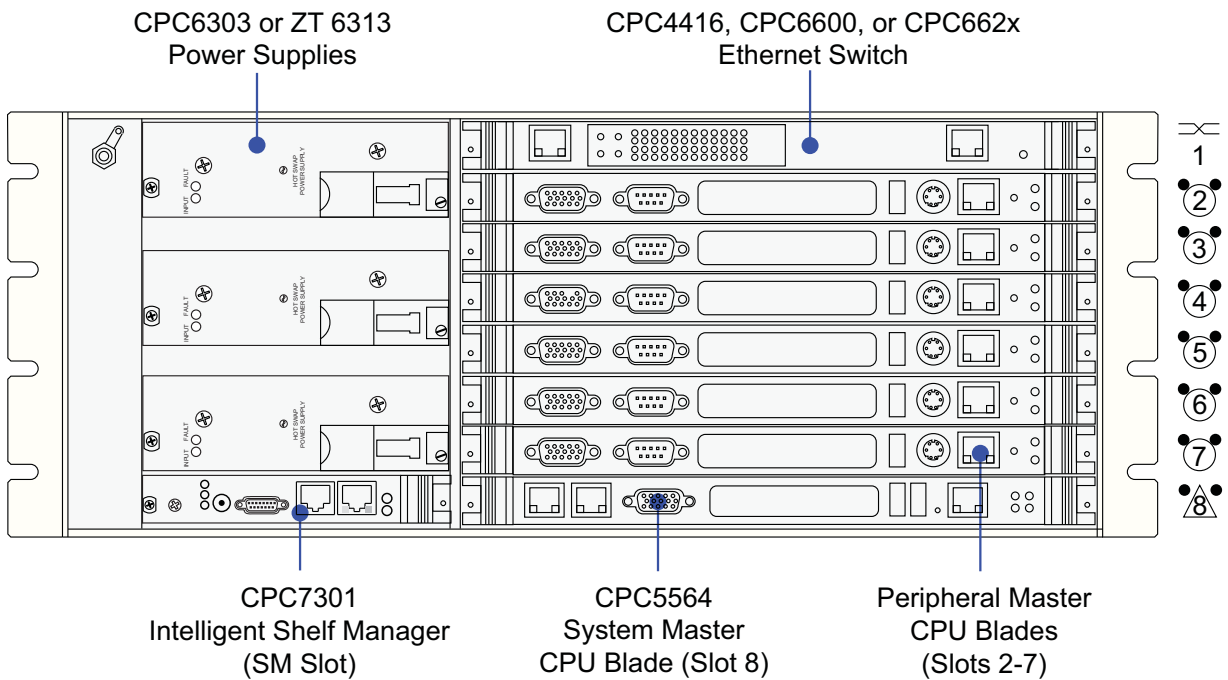
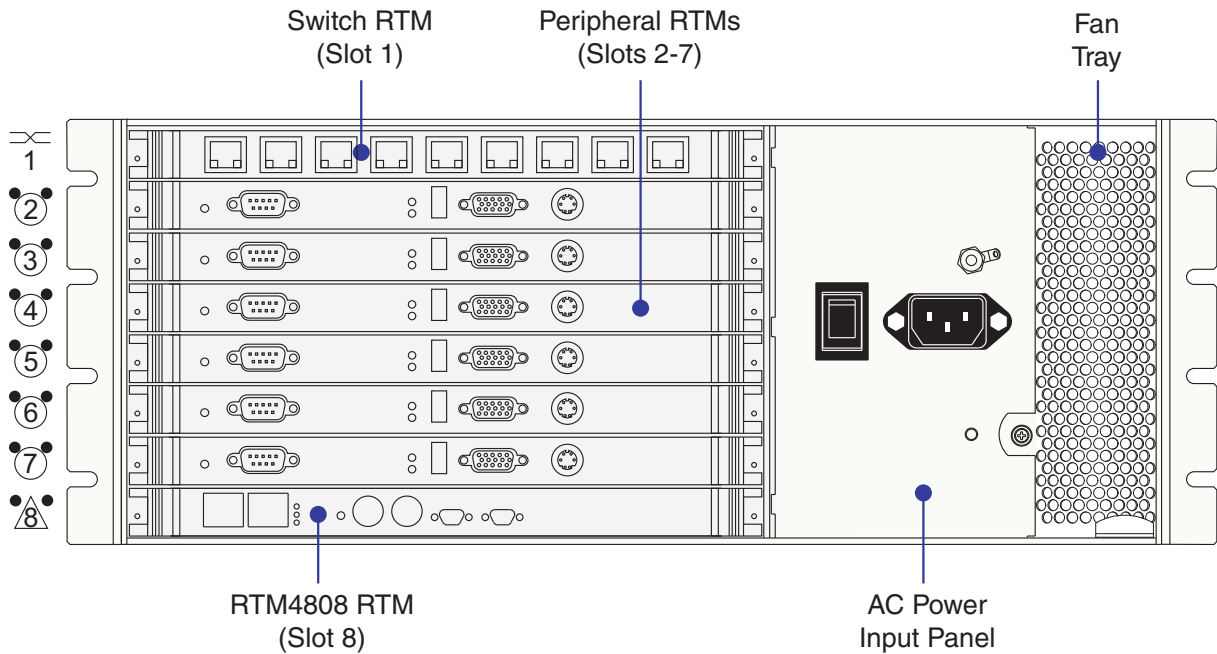

Figure 1-2: Typical AMP System with a Loaded AMP5091 Chassis — Rear View

Chassis Hardware Configuration - 4U Chassis, AMP5091

The following steps describe how to configure your chassis hardware.

1. Unpack the box.
2. Ensure that all cover panels are in place and that all component slots are populated with a component. Those slots that are not populated must be filled with an air management blade in any front slots, or covered with a blank filler panel for those unpopulated rear board slots and/or power supply slots.
3. Properly ground the system.
4. Set the board select (**BD_SEL**) jumpers on the midplane. The board select provides the active or inactive state to the power circuitry for each slot component. When **BD_SEL** is active then the power control circuitry allows power to flow into the board. **BD_SEL** can be provided by various options:
 - a. Controlled by ISM
 - b. Via selectable jumpers on the slot component
 - c. Backplane **BD_SEL** jumpers J21-J28 (see [Figure 1-3, "BD_SEL# Jumper Locations \(J21-J28\)," on page 10.](#))
 - All jumpers in for system with no ISM
 - All jumpers out for system with an ISM

Figure 1-3: BD_SEL# Jumper Locations (J21-J28)

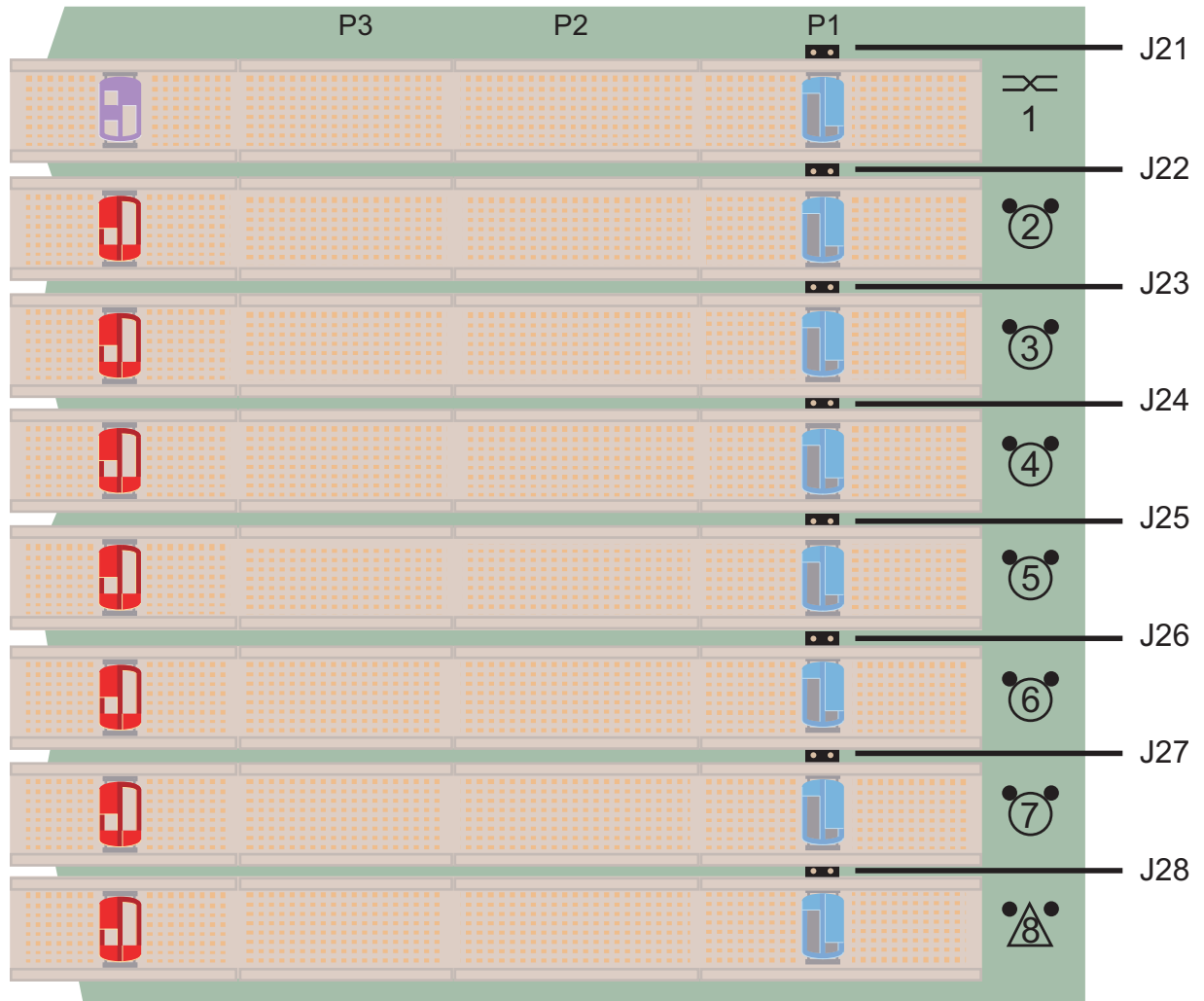

5. Set the VIO jumper bar on the midplane to either 5V or 3.3V, depending upon your slot component's specification. See [Figure 1-4, "V I/O Selection,"](#) on page 11 below.

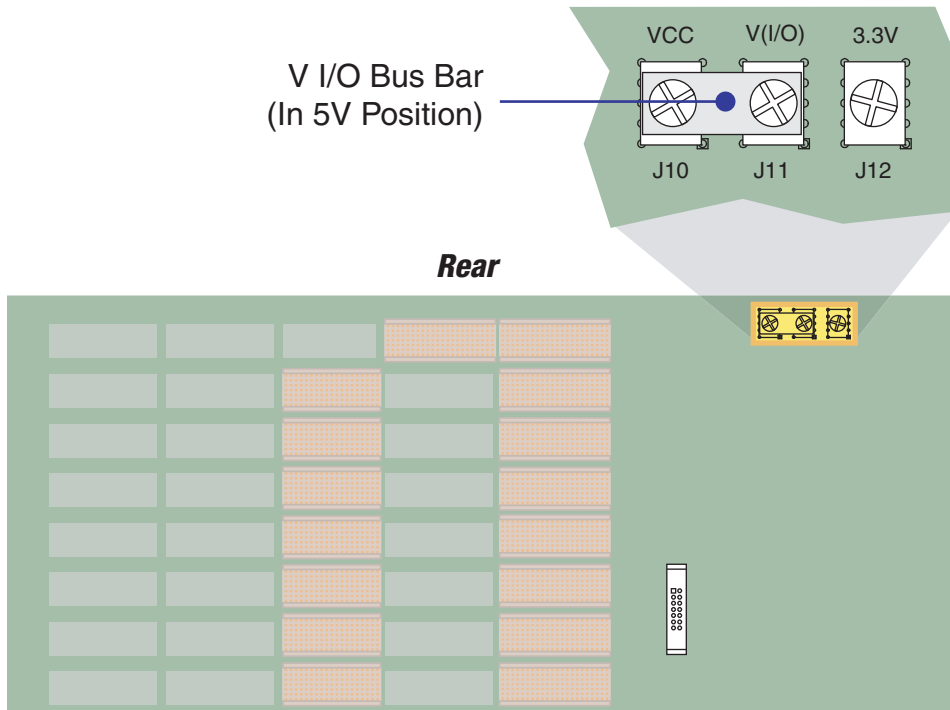
Figure 1-4: V I/O Selection

6. For the AMP5091chassis, you must set the IPMB power jumper bar to either:
 - a. Keep the jumper bar between the VCC and IPMB.
 - OR-
 - b. To connect IPMB Power to a remote power supply, remove the bus bar between VCC and IPMB, and connect the remote voltage to IPMB and its ground to the GND screw located next to the IPMB and VCC screws.

See [Figure 1-5, "IPMB Power Selection,"](#) on page 12.

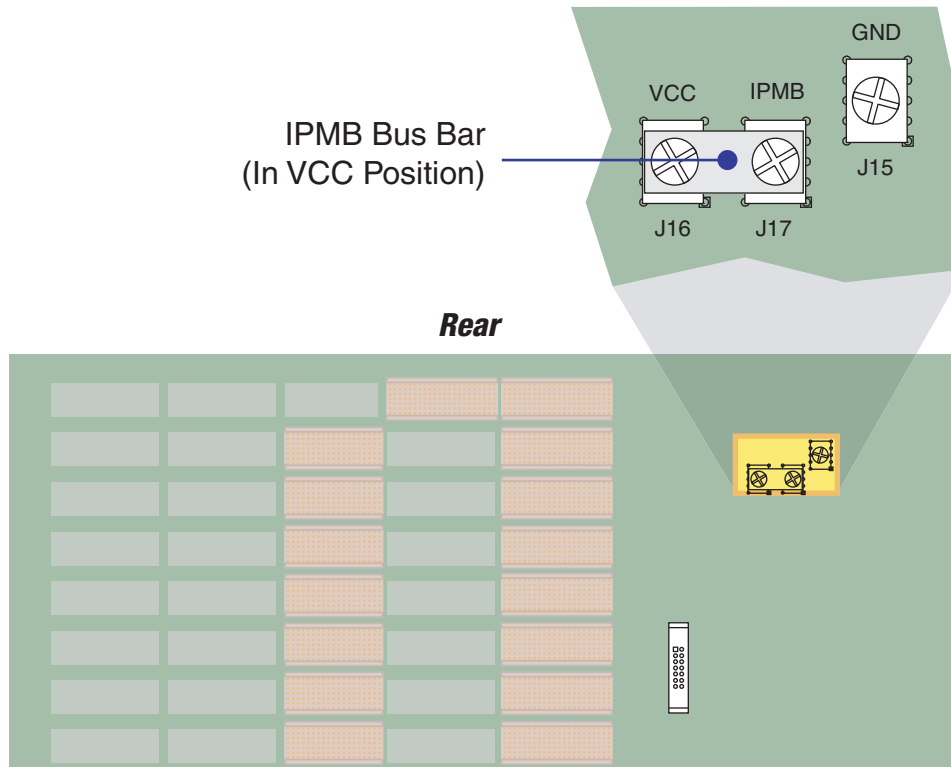
Figure 1-5: IPMB Power Selection

ISM Hardware Configuration

Please locate and refer to the *CPC7301 Intelligent Shelf Manager Hardware Manual* to assist with the following steps.

Configure the ISM Hardware

1. Set **SW2-1** to the desired position:
 - Open **SW2-1** to allow software to direct **eth0** signals to the front panel or rear panel connector (The ISM comes out of reset with **eth0** routed to the front panel, but software can be configured to automatically route **eth0** to the rear panel.)
 - Close **SW2-1** to force **eth0** signals to the front panel connector. Factory default is Open.
2. Install the ISM back into the chassis in the appropriate slot.
3. Install the RTM, if included, into the appropriate slot in the rear of the chassis.

Ethernet Switch Hardware Configuration

Please locate and refer to your *Ethernet Switch User's Manual* to assist with the following steps.

Configure Ethernet Switch Hardware

1. Review the *Hardware Manual* and set switches and/or jumpers for each Ethernet Switch board and RTM type you selected, being careful to understand how you wish to use the fabric-to-fabric link.
2. Install, or re-install, the switches in their respective fabric slots (as identified by the *Chassis Manual* or the glyph  on the front of the chassis).
3. Install, or re-install, each RTM into the slot at the rear of the chassis corresponding to their appropriate fabric board mate.

Power up the System

Once all safety steps have been adhered to, and the chassis is wired according to all applicable regulations and per the instructions in the applicable chassis *Hardware Manual*, you are ready to proceed to the following steps to power up the system. Have the chassis *Hardware Manual* readily available while performing these steps.

1. Ensure that the power standby switch on the rear of the chassis is in the **standby** () position.
2. For AC systems, all available plugs must be connected with the accompanying power cords into an appropriately rated power source. See [Figure 1-6, "AC Input Panel,"](#) on page 14.

Figure 1-6: AC Input Panel



3. For DC systems:

- Connect properly rated wires to the DC power input panel (see [Figure 1-7, "DC Input Panel,"](#) on [page 15](#)) as outlined in the *Hardware Manual*.
- Apply power to these connections via the DC power source.

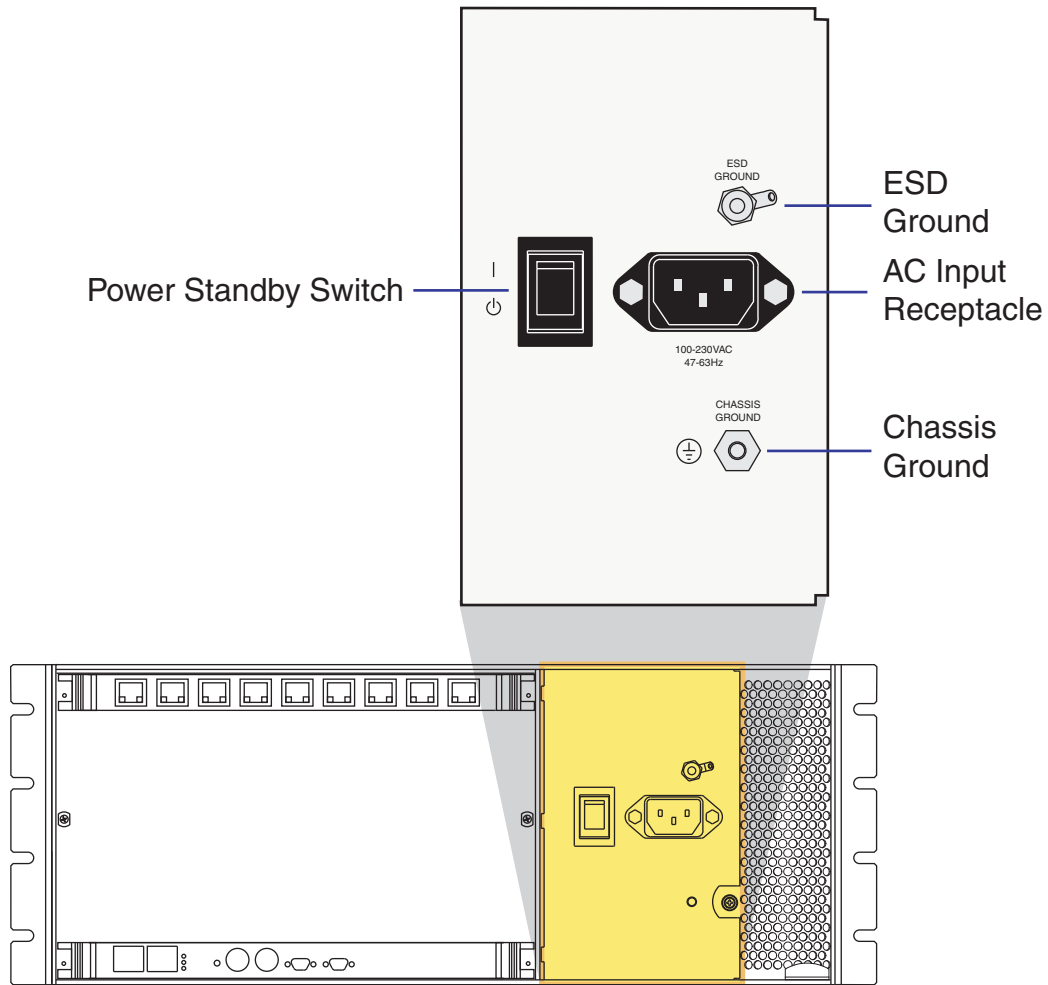
Figure 1-7: DC Input Panel

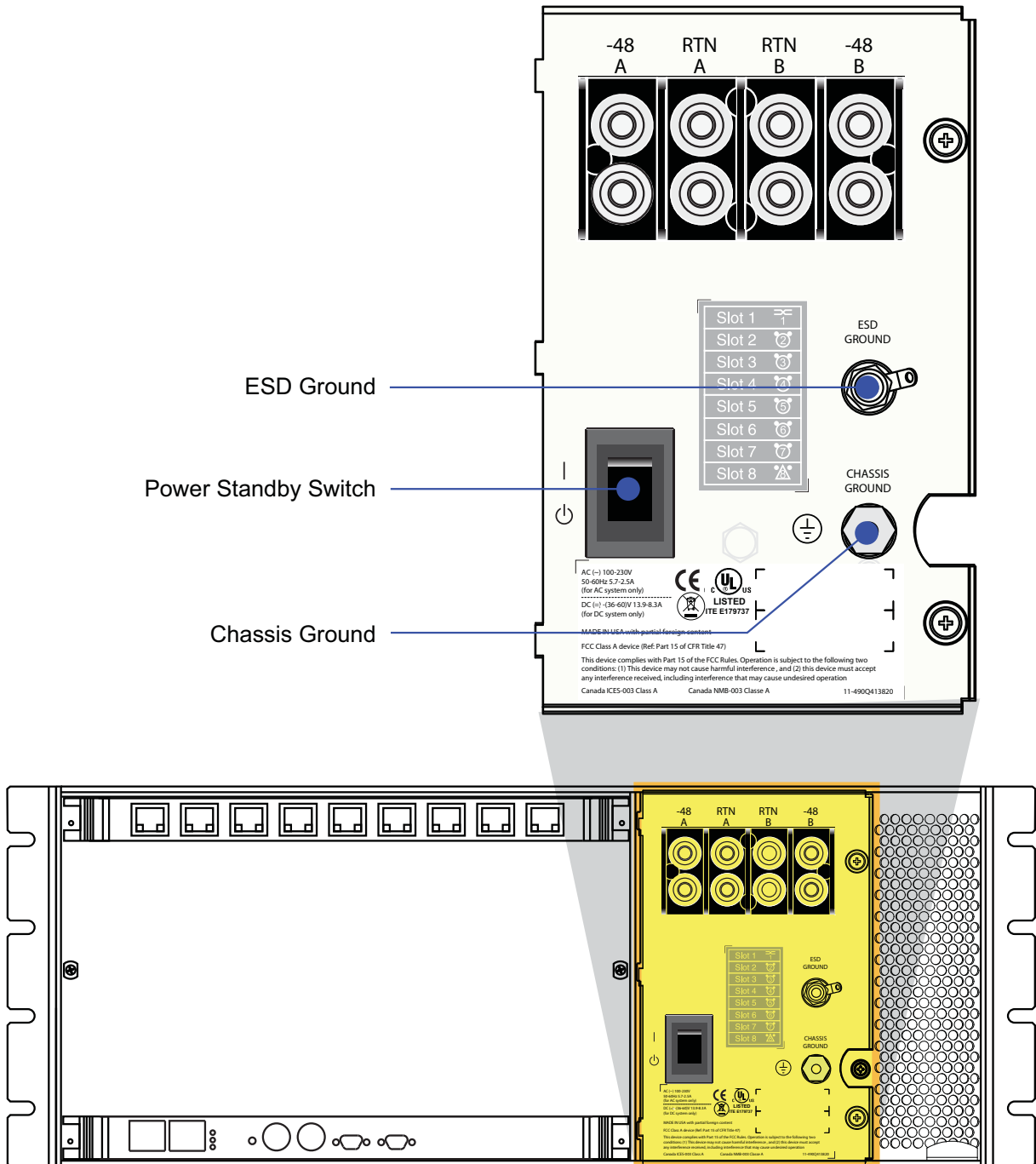

4. Turn the power standby switch on the rear of the chassis to the ON position.
5. Observe all power supply LEDs through the screen cover from the front of the chassis. They should all be green. If there are red LEDs, please ensure the power supply is seated correctly. If LED is still red, contact Technical Support.
6. If possible, observe all fans to ensure they are all running properly. Some chassis models will have LEDs on the fan trays.

7. Observe all board LEDs to ensure that the blue, hot-swap LED goes out after approximately one to two minutes. If they do not, connect to the console port and observe the boot sequence, then contact Performance Technology Technical Support:

<http://www.pt.com/support/>.

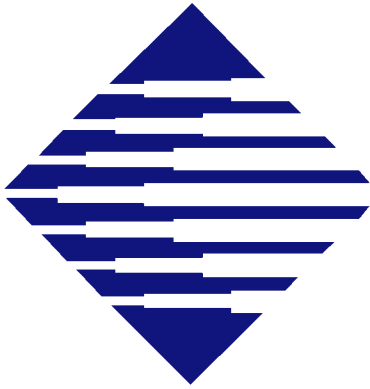

Setting Up the Components

Overview

This chapter describes how to set up the Ethernet switch and the ISM. The key topics in this chapter include:

- [“Ethernet Switch Set-up,” on page 17](#)
- [“ISM Set-up,” on page 18](#)
- [“Setting up the ISM Graphical User Interface \(GUI\),” on page 21](#)

Ethernet Switch Set-up

There are several ways to communicate with the Performance Technologies' Ethernet Switch, but for initial configuration, connect via the serial console port. After the initial IP addresses are input and saved, you can connect via telnet session through one of the Ethernet ports (either the out-of-band management port **mgmt0**, or one of the in-band Ethernet ports).

After the switch has completed the Boot Process, it is operational. Once operational, you can log into the switch and configure an IP address for each or any of the switches IP interfaces (Out-of-Band Management and up to 16 switch interfaces).

The following steps describe how to configure the IP settings of the board.

1. Connect a terminal or workstation running terminal-emulation software to the console port. Refer to the “RS-232 Console Port” section of the *User's Manual* for pin connection information.
2. At the Login prompt, type:

```
admin
```

3. At the Password prompt, type:

```
password
```

4. By default, Performance Technologies' Ethernet switches come pre-configured as **Layer 2** switches only.

If you want to have a remote interface to the switch, you can assign a unique IP address and sub-network mask for the management port (**mgmt0**) ONLY! This IP Address may be used as a dedicated communication channel to manage the switch via its processor and IP stack via the Management port only.

The following example defines an IP address and subnet for the management port.

```
# ip config mgmt0 192.168.2.33 255.255.255.0
```

5. To set up a switch as a **Layer 3** switch:

- a. First assign an IP address and subnetwork mask for the management port (**mgmt0**). Be sure that the Management Port IP address is in a different subnet than the Switch Port IP address. For example:

```
# ip config mgmt0 192.168.2.33 255.255.255.0
```

- b. Then assign an IP address and subnetwork mask for the Switch Port IP Interface (**sw0**). This IP Address may be used to communicate with the CPC660x IP stack via a switched port.

```
# ip config sw0 192.167.1.33 255.255.255.0 1
```

- c. Lastly, assign a gateway address for the switch if you want it to access an address outside of the current subnetwork. You will not have to set this parameter if you are only using the switch on an internal network. To set the gateway address type the following, substituting your own IP address:

```
# ip gateway 192.168.1.101
```

6. Save your configuration settings so they will be in effect after a switch reboot:

```
# save
```

7. When you are finished initializing the configuration, log out of the switch by typing:

```
# exit
```

8. Repeat steps 1-7 for the second Ethernet switch if available. Be sure to correctly differentiate the IP addresses and subnets on the second switch based on your desired topology.

ISM Set-up

There are two ways to communicate with the ISM, via the console port, or via a telnet session through one of its Ethernet ports (see [Figure 2-1, "ISM Front Panel," on page 19](#)). The ISM Ethernet ports come configured with default IP addresses. This allows the user to telnet into the ISM via an IP address that is predefined and documented in the *CPC 7301 Intelligent Shelf Manager Software Manual*.

There are three available physical Ethernet interfaces for the ISM:

- **eth0** (LAN0) - available via RJ45 connectors on the front panel, or the Rear Transition Module (RTM). By default, this is configured out the front panel, and with an IP address of 192.168.0.1.
- **eth1** (LAN1) - connected to the PICMG 2.16 fabric through the midplane, allowing communication via the cPCI Ethernet Switch blades. By default, this interface is not enabled.

- **eth2 (LAN2)** - Used as a synchronization channel between two ISM's via the RTM, or as a second connection to the PCIMG 2.16 fabric, or not connected at all. By default, this interface is configured as the synchronization channel.

Figure 2-1: ISM Front Panel

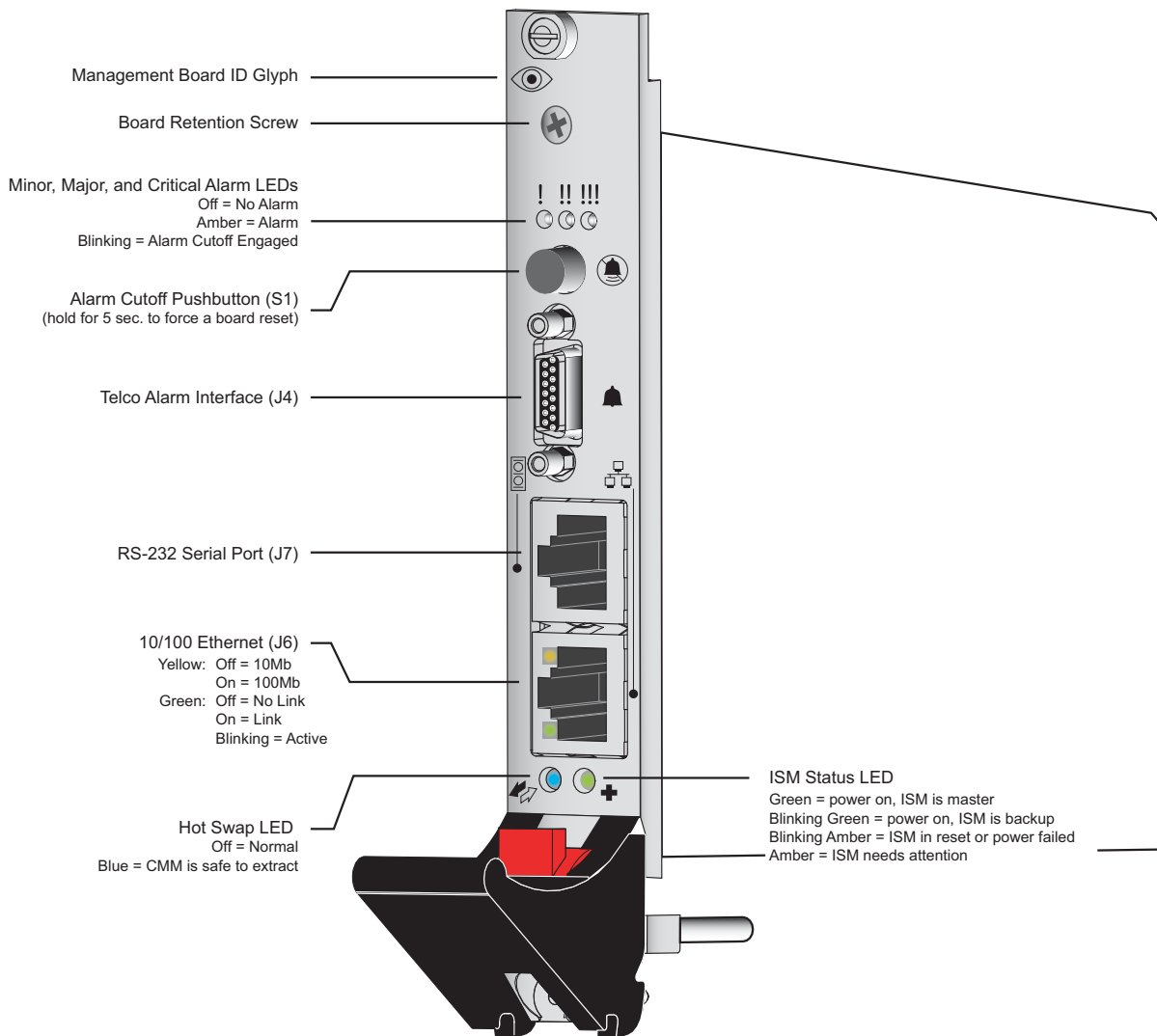

Configuring the ISM on a Local Network

For the purposes of this document, we will have the user place the ISM on a local network making the ISM interface available to any user on the network or, if the local networked is accessible out of the building, any user located remotely. We will do this using **eth1** over the 2.16 network on the midplane.

Configure One ISM on a Local Network

1. Connect to a terminal or workstation running terminal-emulation software to the console port of the ISM. You will need:
 - a. A serial cable with proper pin connections for the ISM console port as described in the current *CPC7301 Intelligent Shelf Manager Hardware Manual*.
 - b. Set your terminal emulation software to connect at 9600, N, 8, 1.

-OR-

- a. Connect to the ISM via a telnet session and the **eth0** front panel RJ45 connector interface. The default IP address is **192.168.0.1**.
2. Log in to the system by typing the following:

```
Login: root
Password: (none by default, just press ENTER)
```

3. At the # prompt, configure the ISM by typing the following commands (substitute the IP addresses and subnetmasks that apply to your local network):

```
bootvars set rc_ifconfig y
bootvars set rear_eth_connector=n
bootvars set ethprime i82559#1
bootvars set ipdevice eth1
bootvars set ipaddr 10.178.46.81
bootvars set netmask 255.255.255.0
bootvars set active_device eth1:1
bootvars set active_ipaddr 10.178.46.83
bootvars set active_netmask 255.255.255.0
bootvars set gateway 10.178.46.1
bootvars set network_reset y
reboot
bootvars print (after the ISM reboots, in order to verify the IP
addressing)
```

Note: *IP configurations changes will not take effect until the system is rebooted. If you performed the configuration changes over a telnet session, you need to start a new telnet session with the new Active IP address; otherwise, you can just log in again at a serial console window.*

4. Once the ISM has rebooted, check the changes you made, log in again as `root`, press ENTER for the password.
5. At the # prompt, type: `ifconfig`. This will display all the IP settings for the Ethernet ports. You should see that **eth1:1** will be set with your IP address and the mask you entered.
6. Next, type `route`. The default Gateway should be the gateway you entered.

The above set of boot variables configures the ISM with **eth1** as the local interface and **eth1:1** as the active interface. The active interface is the main interface for remotely querying and configuring the ISM and connecting to the ISM GUI. For more information on setting up and using the ISM GUI, see the sections [“Setting up the ISM Graphical User Interface \(GUI\),”](#) on page 21 and [“Working with the ISM,”](#) on page 23.

Note that in the example above, it is important that the local adapter be assigned to the physical interface **eth1**, while the active port is assigned to the virtual interface **eth1:1**. This is because the physical interface must be configured before the virtual interface, and the ISM software configures the active interface last. For more details on this and other configuration considerations, refer to the *CPC7301 Intelligent Shelf Manager Software Manual*.

Setting up the ISM Graphical User Interface (GUI)

You can now use the ISM GUI to monitor and control your system. The ISM GUI is a simple interface to use that gives you a “picture” of your entire system. Before you attempt to log onto the GUI however, be certain that you have Java Virtual Machine version 1.4.2 or better loaded onto the machine from which you would like to view the GUI. JVM 1.4.2 is a free download at www.java.com.

Set up the GUI

1. Using any web browser on any machine on the LAN, type

```
http://xxx.xxx.xxx.xxx
```

Where xxx.xxx.xxx.xxx is the active IP address of your ISM.

2. If the browser displays a security warning, say YES.
3. After 20 seconds or so, you should see the ISM GUI applet begin and prompt you with a “Connect” dialog box with the following fields:
Host: xxx.xxx.xxx.xxx <- your active IP address for the ISM (as above)
User: ismgui
Password: ismgui
Click on Connect

Note: If not, go back to the section “ISM Set-up,” on page 18 to check ISM IP configuration. Check the Ethernet cable and look for a link light on the front of the ISM.

4. The ISM GUI should come on the screen displaying the system and the boards that are loaded, as shown in [Figure 2-2, “ISM GUI Display Screen,”](#) on page 22. There are more details on the ISM GUI in [Chapter 3, “Communicating Between Components,”](#) on page 23.

Figure 2-2: ISM GUI Display Screen

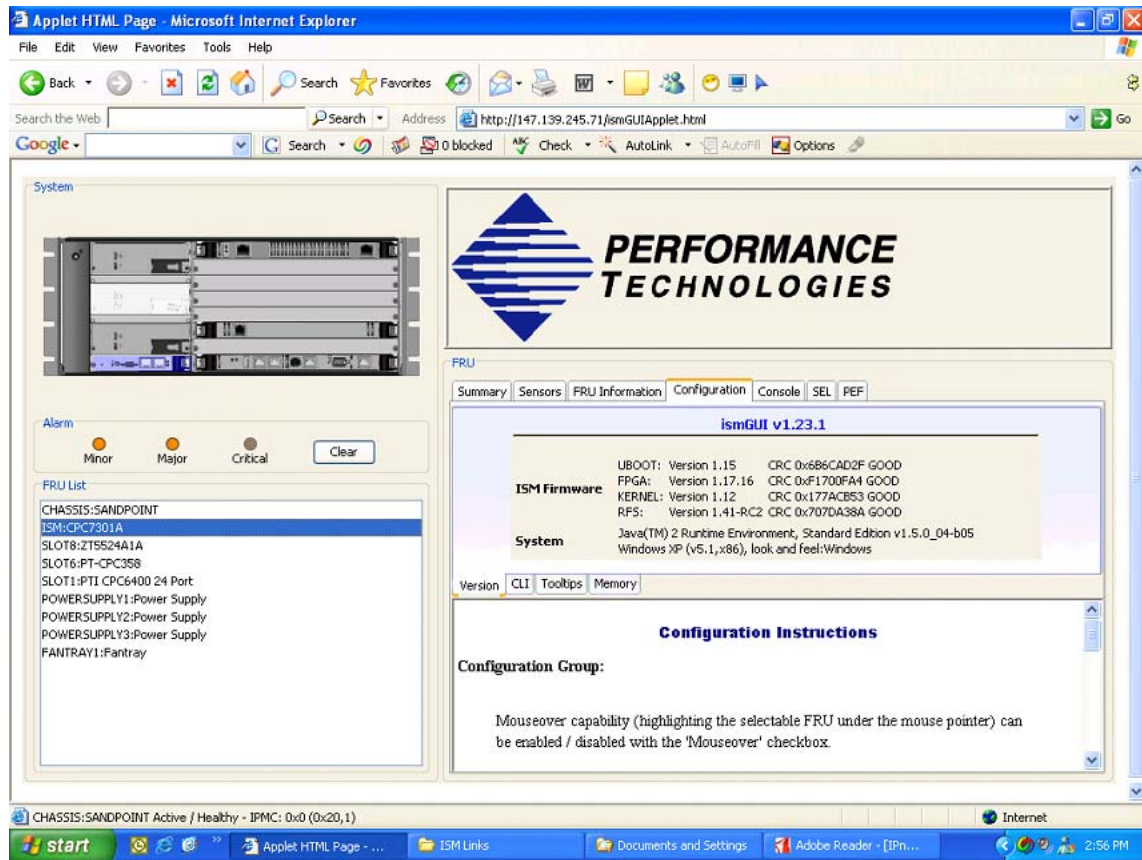

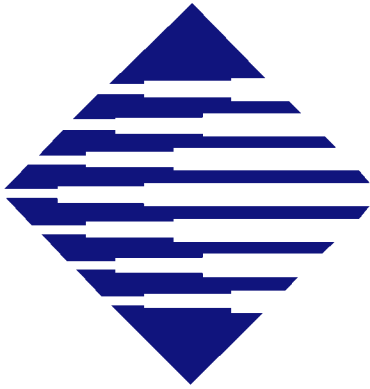

Communicating Between Components

Overview

The chapter describes useful commands for communicating between and obtaining useful analytical information from the Advanced Managed Platform slot components.

The key topics in this chapter include:

- [“Working with the ISM,” on page 23](#)
- [“Working with the Ethernet Switches,” on page 25](#)

Working with the ISM

When working with the ISM, you can use the following:

- ISM CLI commands
- ISM GUI
- Boot environment variables

Using ISM CLI Commands - Operational Information

CLI commands are useful for retrieving information from the system including FRU, sensor, and SEL data. CLI commands are also used for setting operational parameters.

CLI commands can be entered through the serial console or telnet. At the Linux # prompt, the user can type `clia <cli command name>` and press ENTER. Or, the user can switch to the CLI prompt by typing `clia` at the # prompt and pressing ENTER.

Note: Most CLI commands are not resilient and the actions caused by the execution of a CLI command may be nullified upon a reboot of the system/ISM. If you want to have such commands be “resilient,” it is necessary to use them in a script that is executed upon boot-up.

Some Useful CLI Commands for the ISM

<code>GetTsInfo</code>	A script that collects debug information for analysis. You can redirect to a file, then E-mail to Technical Support if necessary for assistance in troubleshooting a problem.
<code>Bootvars print</code>	Prints current boot variables
<code>Ifconfig</code>	Shows runtime network configuration.
<code>clia help</code>	Provides a list of CLI commands.

Using the ISM GUI

Once you are logged into the GUI (see [“Using ISM CLI Commands - Operational Information,” on page 23](#)) you can see a graphic display of the system. The display actively models the chassis and the components within the chassis. If the system changes by adding or removing a board, the graphic display will change as well. This graphic is also functional. With the mouse, you can:

Highlight a board and click to display details. There is good information and functionality available here. For example the user can:

- Look at Summary information to get details about the board. The **Summary** tab also has Actions which may include Activate, Deactivate, or Reset the board.
- Display all current data from the sensors on the board using the **Sensors** tab. (*Note: If polling is turned off, sensor data will not be current.*)
- Obtain FRU information via the **FRU** tab.
- Check the *Release Notes*.
- The **Configuration** tab provides a means of changing the polling rates for detecting sensors, FRUs, sensing alarms, and the rate at which the System Event Log (SEL) is checked. It is NOT recommended that you alter any of these settings.
- The **Console** tab provides a quick means of entering CLI commands. However, this is NOT the preferred way to interface with the ISM if you wish to make changes using CLI. The preferred method is via the serial console or telnet. The reason is that polling must be turned off to stop the screen scrolling. The danger is not remembering to turn polling back on once the changes have been made.

If a board is NOT recognized by the GUI it will have a question mark over the space to signify that detailed information is unavailable. This does not indicate that the board will not function in the system—it just means either of the following:

- The board does not implement IPMI, therefore, the ISM GUI cannot determine the make/model (no FRU information).
- OR-
- This board does not have a specific configuration for the ISM GUI (graphic and summary page). The board will function properly but the graphical representation of the board and the summary information will be limited.

Using Boot Environment Variables - Configuring the ISM

Boot environment variables are options that can be used to customize the boot behavior of the ISM to match the needs of an application.

A few examples of boot variables are:

- Setting an ISM password. By default, there is no password. Setting a password obviously adds security to the system.
- Directing **Ethernet 0** to the front panel (default) or the Rear Transition Module.
- Reset the flash file system to defaults.
- Set IP addresses for the Ethernet ports

The `bootvars` command at the Linux # prompt is used to set boot environment variables. It is important to note that the boot environment variables are saved upon a reboot. Be aware, however, that changes to the boot variables `active_ipaddr`, `active_netmask`, and `gateway` require you to enter the following command before rebooting the ISM:

```
bootvars set network_reset y
```

Boot environment variables are described further in *Chapter 2, "Location of Configuration Data,"* of the *CPC7301 Intelligent Shelf Manager Software Manual*.

Working with the Ethernet Switches

There are a large number of commands used to manage, monitor, and operate the Ethernet Switches. Please refer to your *Ethernet Switch User's Manual* for a complete listing of the available commands and the proper syntax.

Using the Ethernet Switch CLI Commands - Operational Information

The following is a script of basic commands that will confirm that the Ethernet switch is operating and useable in your configuration.

1. Connect a terminal or workstation running terminal-emulation software to the console port on one of the Ethernet switches. Refer to the "RS-232 Console Port" section of the *User's Manual* for pin connection information or connect via the management port via Ethernet to the IP address specified in an earlier step.

2. At the Login prompt, type:

```
admin
```

3. At the Password prompt, type:

```
password
```

4. Review the configuration of the switch by typing the following commands:

```
switch display      Shows Ethernet Switch model #, s/n, MAC address, etc.
```

```
switch version      Displays version information on the Ethernet Switch.
```

```
port config all     Displays port configuration information for all ports.
```

```
port link all       Displays link status for all ports.
```

`ip arp display` Lists the contents of the arp table.
`vlan show` Displays VLAN information across all ports on the Ethernet Switch.
`ip stats sw[0-15]` Displays IP information for all switch interfaces.
`ip stats mgmt[0]` Displays IP information on the management interface.
`fdb learned all` Displays the entries in the dynamic filtering database.
`span bridge show` Displays Spanning Tree status information.

5. You can communicate with another device on the network by using the ping command:

```
ping [IP address]
```

6. Repeat steps 1 through 6 on the second Ethernet switch (if present.)